

0

1

2

3

4

5

PROJECT: AGRITE AGPAC 334

ENCLOSURE: HOFFMAN, STEEL, 30" x 24" x 10", CONCEPT

DOOR: OPENS TO THE LEFT

CABLE ENTRY: BOTTOM

NOTES

1. PANEL SPECIFICATIONS:
 NEMA 4 STEEL ENCLOSURE
 CONTROL/ALARM SECTION
 VOLTAGE: 120VAC/24VDC
 LINE VOLTAGE: 120 VAC 1 PHASE

2. DASHED LINES REPRESENT FIELD WIRING REQUIRED.

3. CONNECT GROUND TERMINAL IN BOX TO A GOOD GROUND.

LEGEND

CB1-CIRCUIT BREAKER
 CR-CONTROL RELAY
 PS1 - 24VDC POWER SUPPLY
 D1,2 - DIODE
 R1 - RESISTOR

REVISIONS		
A	12/06/2013	INITIAL DESIGN
B	8/27/2014	UPDATED DESIGN
C	11/17/2014	DEMO PANEL FINAL DESIGN

PAGE	PAGE DESCRIPTION
1	GENERAL INFORMATION
2	ENCLOSURE LAYOUT
3	INCOMING POWER FEED, 24VDC POWER
4	DIGITAL INPUTS
5	DIGITAL OUTPUTS, RELAY CONTACTS
6	ANALOG INPUTS AND OUTPUTS
7	CUSTOMER FIELD WIRING
8	CUSTOMER FIELD WIRING

DEVICE	LABEL	SIZE AND TYPE
PUSHBUTTON	SYSTEM RESET	1" X2" BRADY, BLACK WITH WHITE LETTERS
PUSHBUTTON	START IRRIGATION	1" X2" BRADY, BLACK WITH WHITE LETTERS
PADDLE SWITCH 2-POS	SYSTEM OFF AUTO	1" X2" BRADY, BLACK WITH WHITE LETTERS
PADDLE SWITCH 3-POS	WELL PUMP MAN OFF AUTO	1" X2" BRADY, BLACK WITH WHITE LETTERS
PADDLE SWITCH 3-POS	BOOSTER PUMP MAN OFF AUTO	1" X2" BRADY, BLACK WITH WHITE LETTERS

LEGEND	WIRE COLOR KEY	WIRE COLOR
L1,N	MAIN FEED POWER 120VAC SINGLE PHASE	BLACK
H	120VAC	BLACK
	120VAC SWITCHED	ORANGE
N	NEUTRAL	WHITE
PE	GROUND	GREEN
+	+24VDC	RED/WHITE
-	-24VDC	WHITE/RED
	24VDC SWITCHED	BROWN/WHITE

NOTICE: THIS DRAWING CONTAINS PROPRIETARY INFORMATION AND IT SHALL NOT BE USED OR REPRODUCED OR ITS CONTENTS DISCLOSED IN WHOLE OR IN PART, WITHOUT PRIOR WRITTEN CONSENT.

REV	DESCRIPTION	DATE	DRWN	CHKD	APPD	DRAWN: GWR DATE 12/6/13	CHECKED:	DATE	APPR: GWR DATE 12/23/13
-----	-------------	------	------	------	------	-------------------------	----------	------	-------------------------

DRAWING NO. 13-017	REV. A	SHEET 1 OF 8	SCALE NONE	SIZE: B	TITLE: AgRite Panel
--------------------	--------	--------------	------------	----------------	---------------------

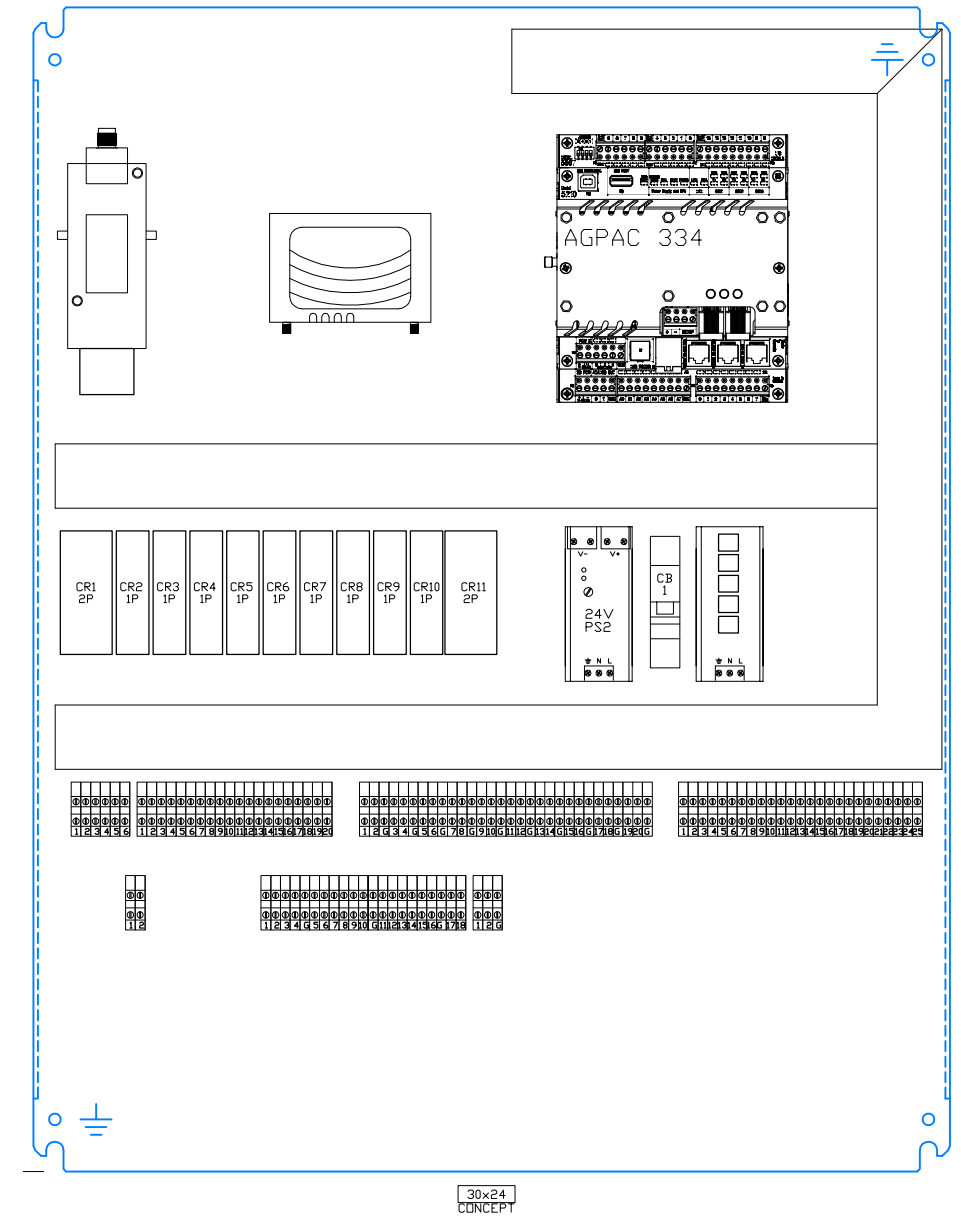
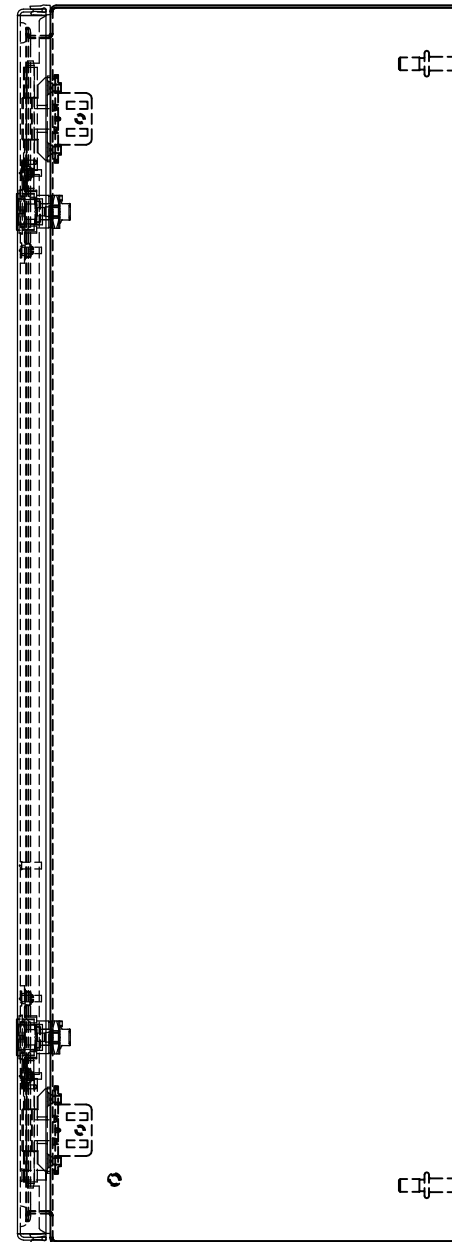
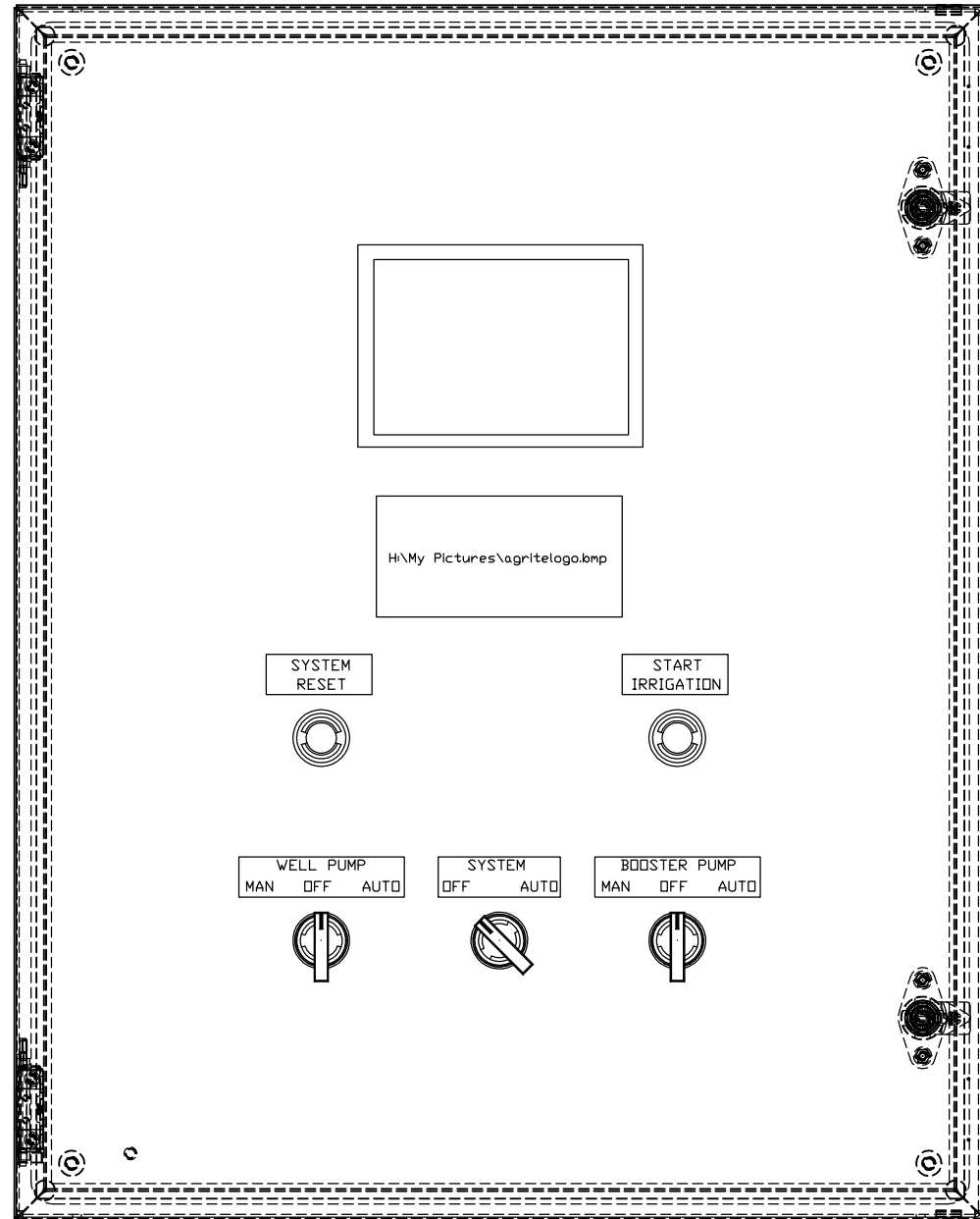

INNERDOOR LAYOUT – DOORS REMOVED FOR CLARITY

NOTICE: THIS DRAWING CONTAINS PROPRIETARY INFORMATION AND IT SHALL NOT BE USED OR REPRODUCED OR ITS CONTENTS DISCLOSED IN WHOLE OR IN PART, WITHOUT PRIOR WRITTEN CONSENT.					DRAWING NO. 13-017		REV. A	SHEET 2 OF 8	SCALE NONE	SIZE: B	TITLE: AgRite Panel
REV	DESCRIPTION	DATE	DRWN	CHKD	APPD	DRAWN: GWR DATE 12/6/13	CHECKED:	DATE	APPR: GWR DATE 12/23/13		

0

1

2

3

4

5

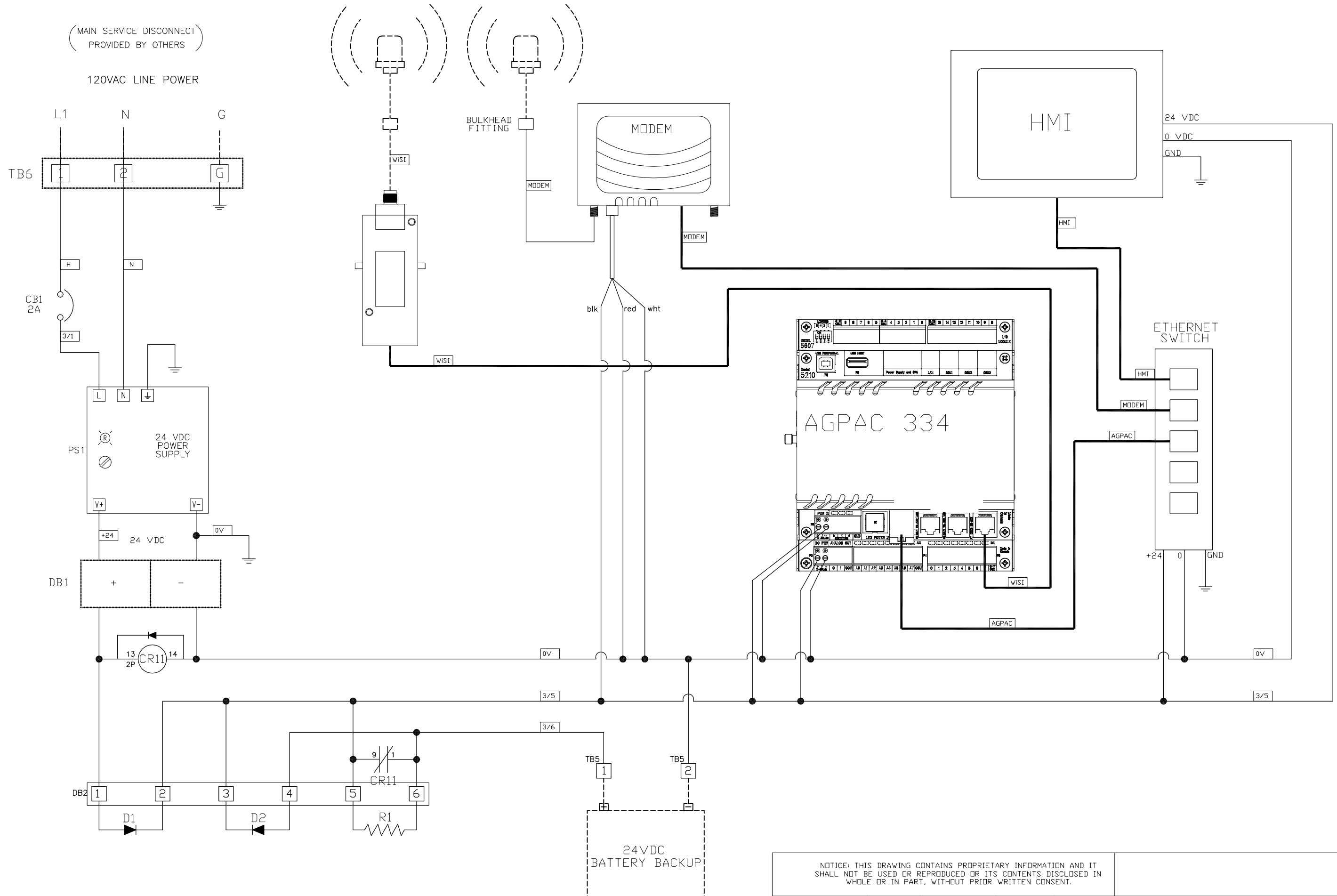

NOTICE: THIS DRAWING CONTAINS PROPRIETARY INFORMATION AND IT SHALL NOT BE USED OR REPRODUCED OR ITS CONTENTS DISCLOSED IN WHOLE OR IN PART, WITHOUT PRIOR WRITTEN CONSENT.

REV	DESCRIPTION	DATE	DRWN	CHKD	APPD	DRAWN: GWR DATE 12/6/13	CHECKED:	DATE	APPR: GWR DATE 12/23/13
-----	-------------	------	------	------	------	-------------------------	----------	------	-------------------------

DRAWING NO. 13-017	REV. A	SHEET 3 OF 8	SCALE NONE	SIZE: B	TITLE: AgRite Panel
--------------------	--------	--------------	------------	---------	---------------------

CUSTOM PANEL SHOP QUOTE # PS 131206GWR1

0

1

2

3

4

5

SCADA PACK
COUNTER INPUTS

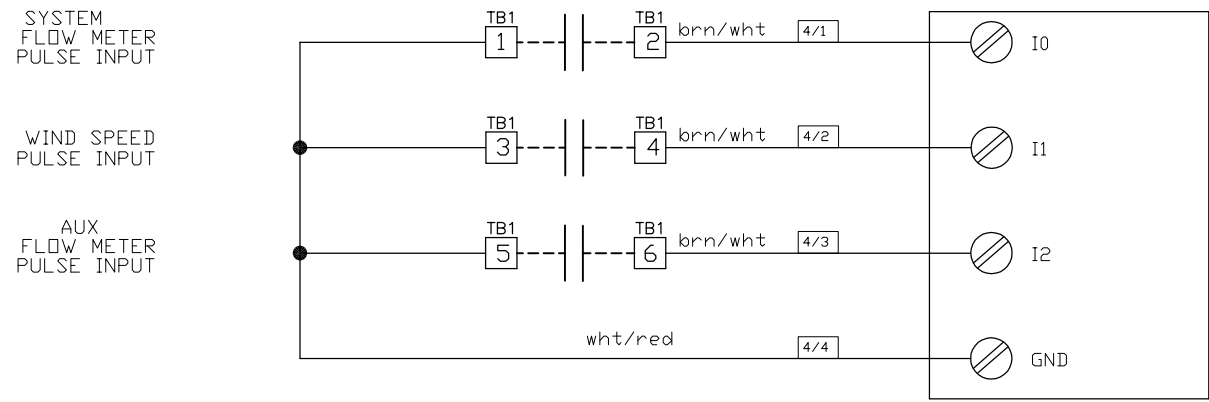

SCADA PACK
24VDC INPUTS

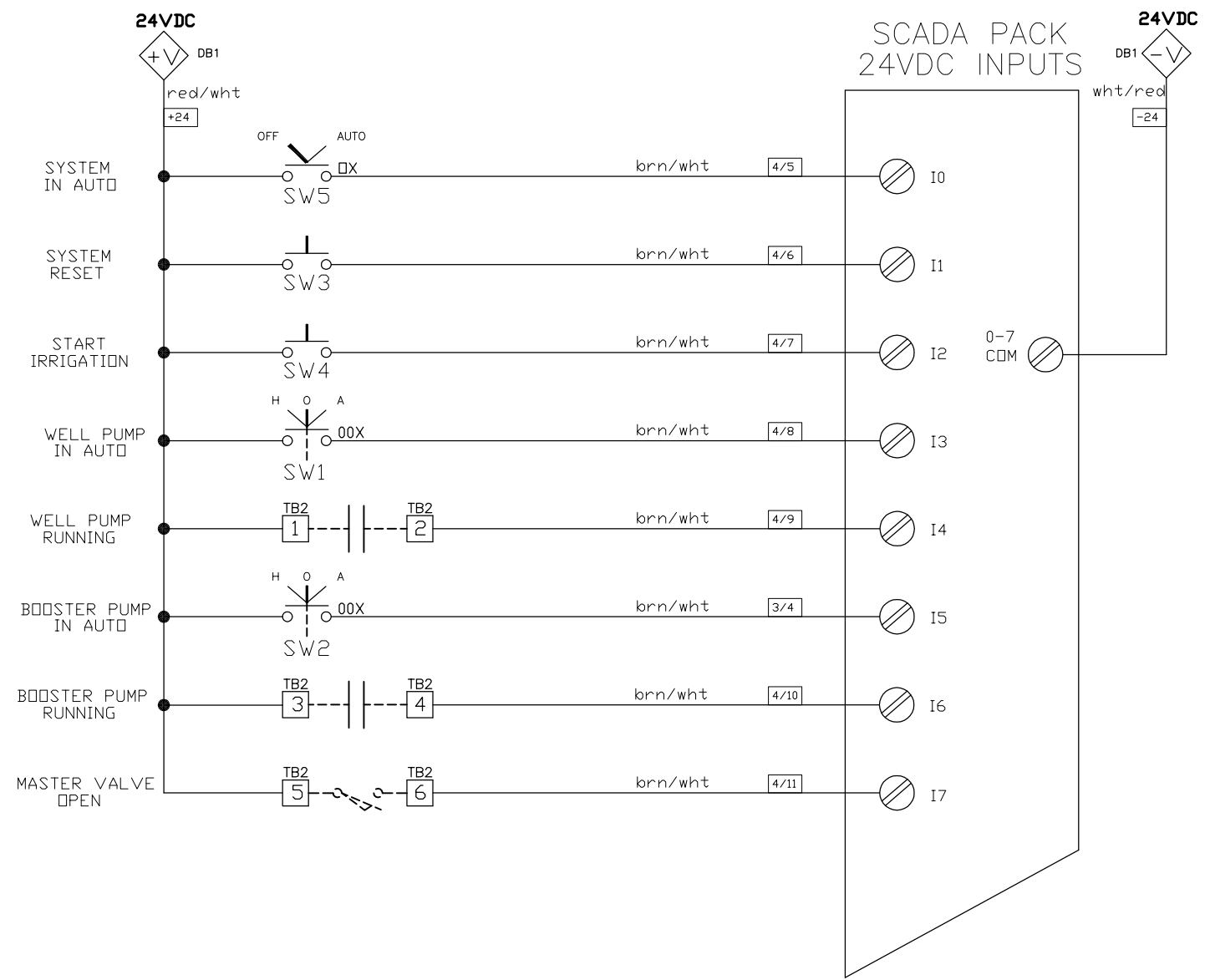

24VDC
+V DB1
red/wht
+24

POWER FAIL

AUX 1

AUX 2

AUX 3

SPARE

SPARE

SPARE

SPARE

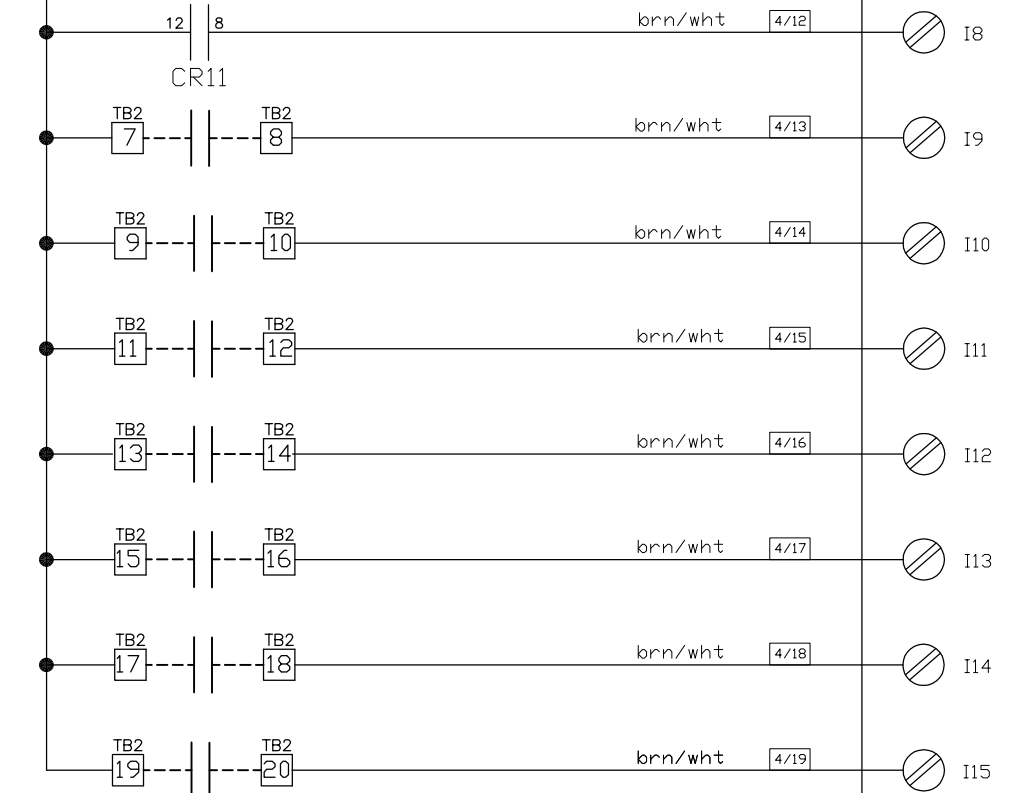

SCADA PACK
24VDC INPUTS

24VDC
DB1
wht/red
-24

8-15
COM

NOTICE: THIS DRAWING CONTAINS PROPRIETARY INFORMATION AND IT SHALL NOT BE USED OR REPRODUCED OR ITS CONTENTS DISCLOSED IN WHOLE OR IN PART, WITHOUT PRIOR WRITTEN CONSENT.

REV	DESCRIPTION	DATE	DRWN	CHKD	APPD	DRAWN: GWR DATE 12/6/13	CHECKED:	DATE	APPR: GWR DATE 12/23/13
-----	-------------	------	------	------	------	-------------------------	----------	------	-------------------------

DRAWING NO. 13-017	REV. A	SHEET 4 OF 8	SCALE NONE	SIZE: B	TITLE: AgRite Panel
-----------------------	-----------	-----------------	---------------	------------	------------------------

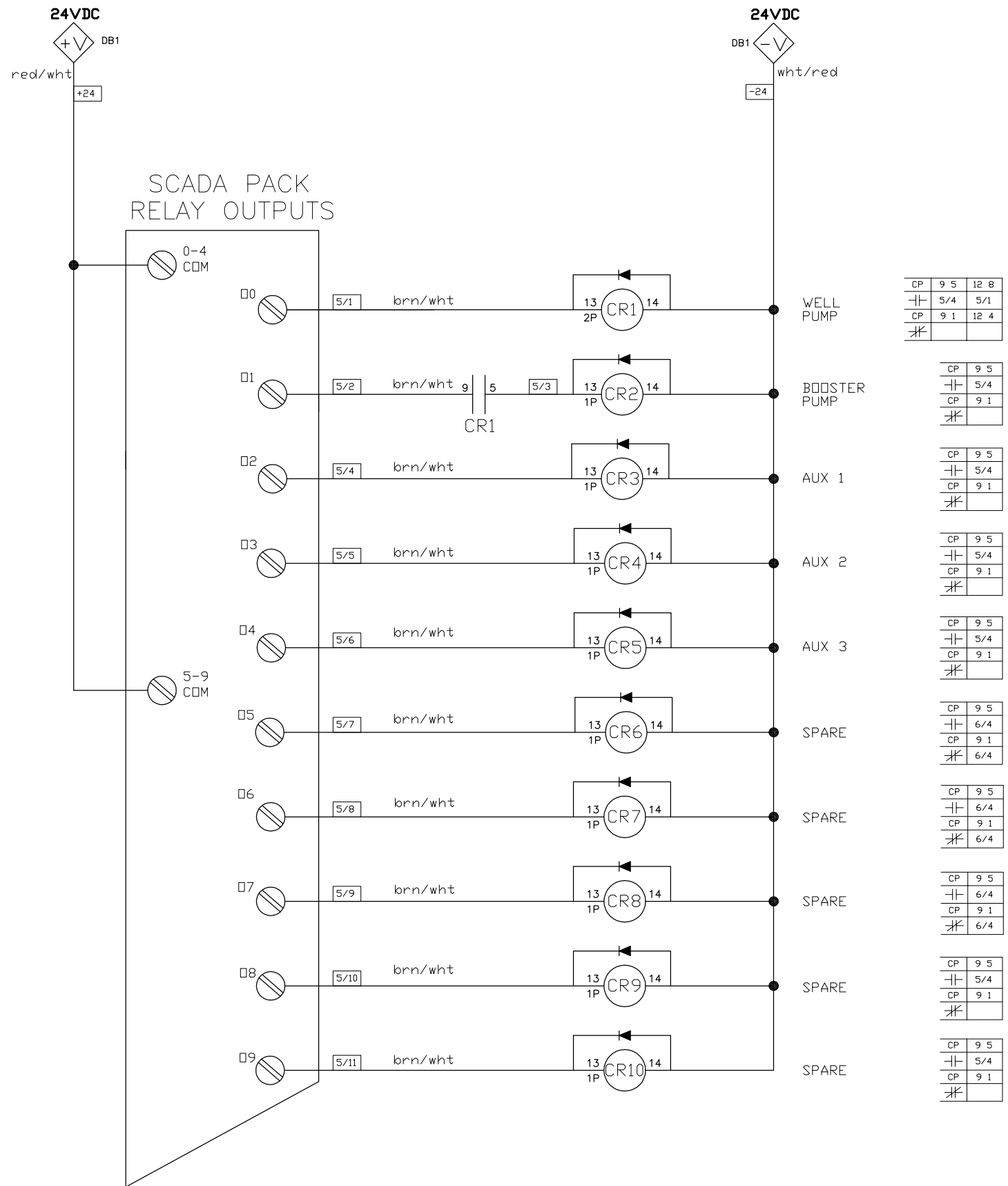

NOTICE: THIS DRAWING CONTAINS PROPRIETARY INFORMATION AND IT SHALL NOT BE USED OR REPRODUCED OR ITS CONTENTS DISCLOSED IN WHOLE OR IN PART, WITHOUT PRIOR WRITTEN CONSENT.

REV	DESCRIPTION	DATE	DRWN	CHKD	APPD	DRAWN: GWR DATE 12/6/13	CHECKED:	DATE	APPR: GWR DATE 12/23/13
-----	-------------	------	------	------	------	-------------------------	----------	------	-------------------------

DRAWING NO. 13-017	REV. A	SHEET 5 OF 8	SCALE NONE	SIZE: B	TITLE: AgRite Panel
-----------------------	-----------	-----------------	---------------	-------------------	------------------------

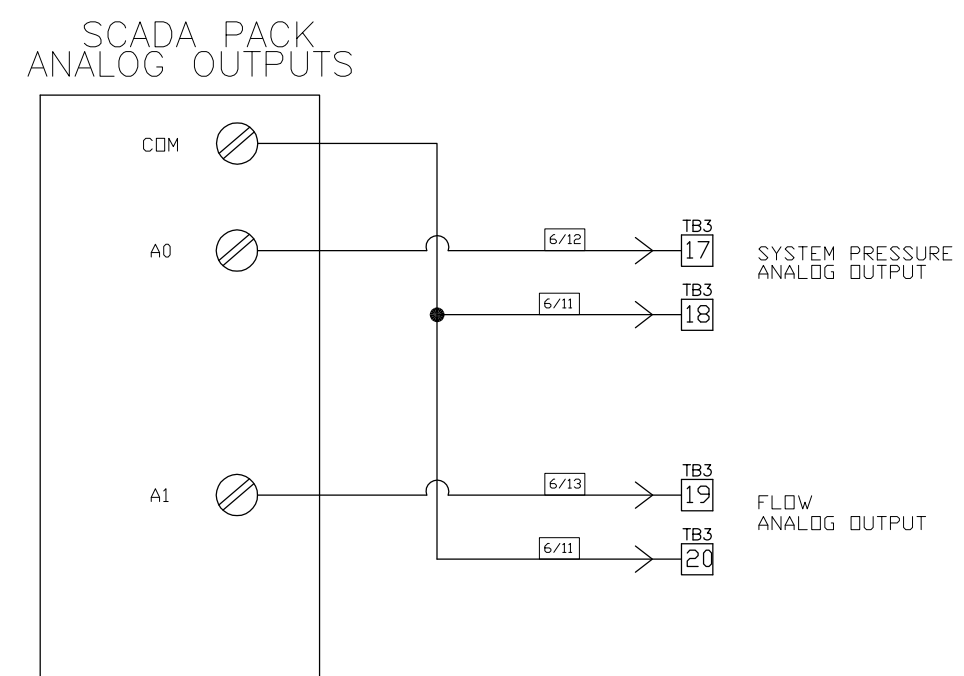
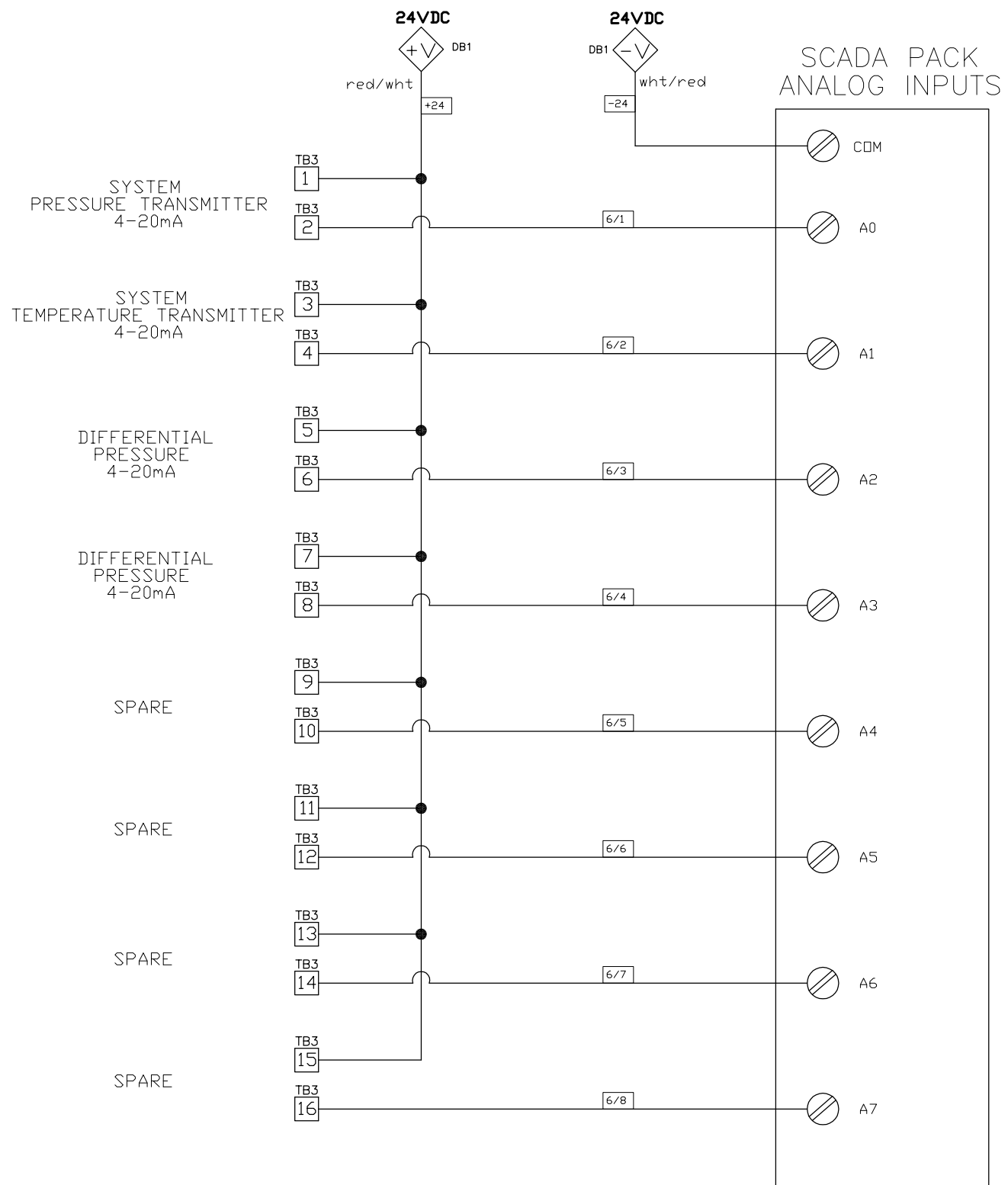

NOTICE: THIS DRAWING CONTAINS PROPRIETARY INFORMATION AND IT SHALL NOT BE USED OR REPRODUCED OR ITS CONTENTS DISCLOSED IN WHOLE OR IN PART, WITHOUT PRIOR WRITTEN CONSENT.					TITLE: AgRite Panel	
DRAWING NO.	REV.	SHEET	SCALE	SIZE:		
13-017	A	6 OF 8	NONE	B		

REV	DESCRIPTION	DATE	DRWN	CHKD	APPD	DRAWN: GWR DATE 12/6/13	CHECKED:	DATE	APPR: GWR DATE 12/23/13
-----	-------------	------	------	------	------	-------------------------	----------	------	-------------------------

FIELD WIRING

DIGITAL AND ANALOG INPUTS AND ANALOG OUTPUTS

TB1
COUNTER
INPUTS

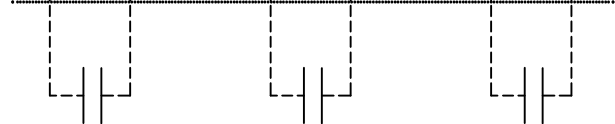
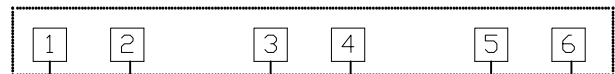

SYSTEM
FLOW METER
PULSE INPUT

WIND SPEED
PULSE INPUT

AUX
FLOW METER
PULSE INPUT

TB2
DIGITAL
INPUTS

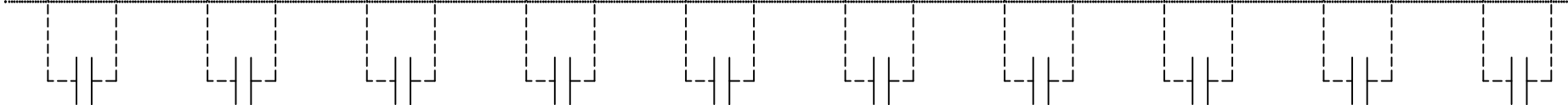

WELL PUMP
RUNNING

BOOSTER PUMP
RUNNING

MASTER VALVE
OPEN

AUX 1

AUX 2

AUX 3

SPARE

SPARE

SPARE

SPARE

TB3
ANALOG
INPUTS

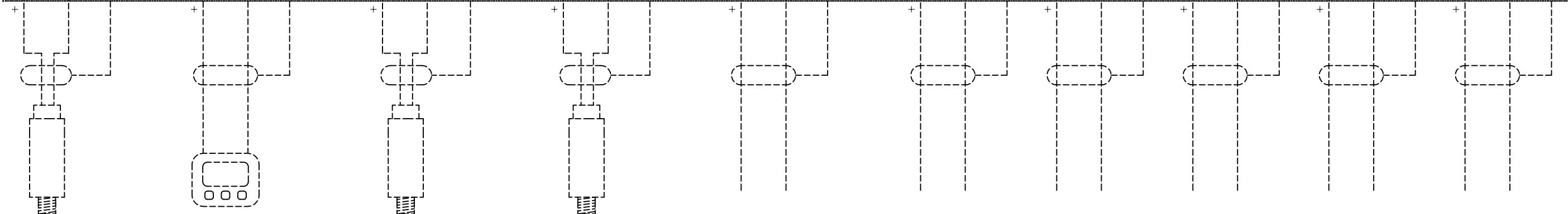
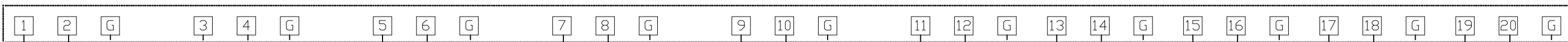

SYSTEM
PRESSURE TRANSMITTER
4-20mA

SYSTEM
TEMPERATURE
TRANSMITTER
4-20mA

DIFFERENTIAL
PRESSURE
4-20mA

DIFFERENTIAL
PRESSURE
4-20mA

SPARE
ANALOG
INPUT

SPARE
ANALOG
INPUT

SPARE
ANALOG
INPUT

SPARE
ANALOG
INPUT

SYSTEM
PRESSURE
ANALOG
OUTPUT

FLOW
ANALOG
OUTPUT

NOTICE: THIS DRAWING CONTAINS PROPRIETARY INFORMATION AND IT SHALL NOT BE USED OR REPRODUCED OR ITS CONTENTS DISCLOSED IN WHOLE OR IN PART, WITHOUT PRIOR WRITTEN CONSENT.

REV	DESCRIPTION	DATE	DRWN	CHKD	APPD	DRAWN: GWR DATE 12/6/13	CHECKED:	DATE	APPR: GWR DATE 12/23/13
-----	-------------	------	------	------	------	-------------------------	----------	------	-------------------------

DRAWING NO. 13-017	REV. A	SHEET 7 OF 8	SCALE NONE	SIZE: B	TITLE: AgRite Panel
-----------------------	-----------	-----------------	---------------	-------------------	------------------------

CUSTOM PANEL SHOP QUOTE # PS 131206GWR1

0

1

2

3

4

5

FIELD WIRING

DIGITAL OUTPUTS AND INCOMING POWER

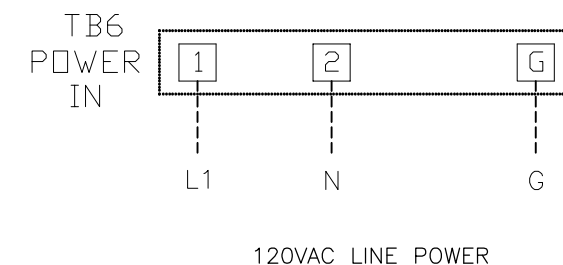
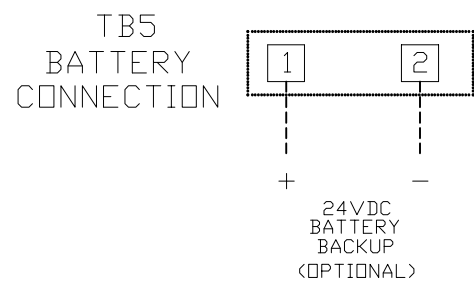
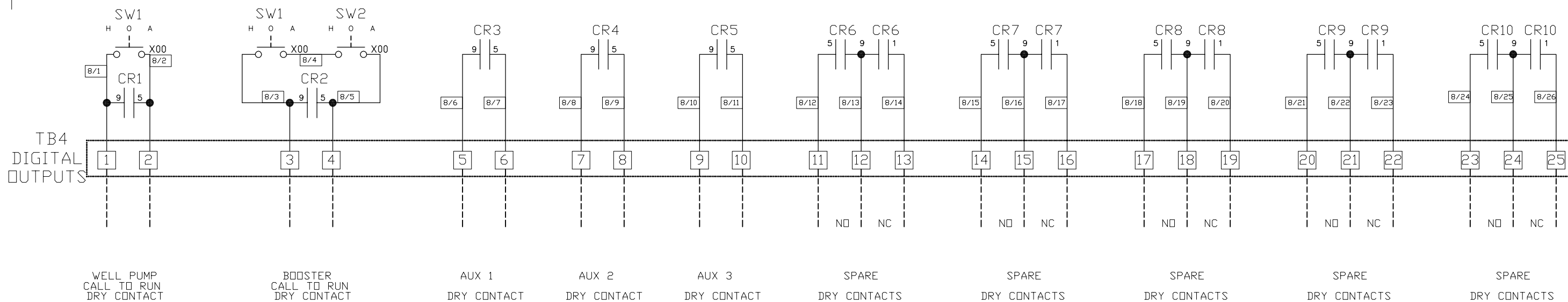

(MAIN SERVICE DISCONNECT PROVIDED BY OTHERS)

NOTICE: THIS DRAWING CONTAINS PROPRIETARY INFORMATION AND IT SHALL NOT BE USED OR REPRODUCED OR ITS CONTENTS DISCLOSED IN WHOLE OR IN PART, WITHOUT PRIOR WRITTEN CONSENT.

REV	DESCRIPTION	DATE	DRWN	CHKD	APPD	DRAWN: GWR DATE 12/6/13	CHECKED:	DATE	APPR: GWR DATE 12/23/13
-----	-------------	------	------	------	------	-------------------------	----------	------	-------------------------

DRAWING NO. 13-017	REV. A	SHEET 8 OF 8	SCALE NONE	SIZE: B	TITLE: AgRite Panel
-----------------------	-----------	-----------------	---------------	-------------------	------------------------